

# 5.

---

## Physical design of WSP

The process design prepared as described in Section 4 must be translated into a physical design. Actual pond dimensions, consistent with the available site, must be calculated; embankments and pond inlet and outlet structures must be designed and decisions taken regarding preliminary treatment, parallel pond systems and whether or not to line the ponds. By-pass pipes, security fencing and notices are generally required, and operator facilities must be provided.

The physical design of WSP must be carefully done: it is at least as important as process design and can significantly affect treatment efficiency.

### 5.1 POND LOCATION

Ponds should be located at least 200 m (preferably 500 m) downwind from the community they serve and away from any likely area of future expansion. This is mainly to discourage people from visiting the ponds (see Section 5.9). Odour release, even from anaerobic ponds, is most unlikely to be a problem in a well-designed and properly maintained system, but the public may need assurance about this at the planning stage, and a minimum distance of 200 m normally allays any fears.

There should be vehicular access to the ponds and, so as to minimise earthworks, the site should be flat or gently sloping. The soil must also be suitable (see Section 5.2). Ponds should not be located within 2 km of airports, as any birds attracted to the ponds may constitute a risk to air navigation.

## 5.2 GEOTECHNICAL CONSIDERATIONS

Geotechnical aspects of WSP design are very important. In Europe, for example, half of the WSP systems that malfunction do so because of geotechnical problems which could have been avoided at the design stage.

The principal objectives of a geotechnical investigation are to ensure correct embankment design and to determine whether the soil is sufficiently permeable to require the pond to be lined. The maximum height of the groundwater table should be determined, and the following properties of the soil at the proposed pond location must be measured:

- (a) particle size distribution;
- (b) maximum dry density and optimum moisture content (modified Proctor test);
- (c) Atterberg limits;
- (d) organic content; and
- (e) coefficient of permeability.

At least four soil samples should be taken per hectare, and they should be as undisturbed as possible. The samples should be representative of the soil profile to a depth 1 m greater than the envisaged pond depth.

Organic, for example peaty and plastic soils and medium-to-coarse sands, are not suitable for embankment construction. If there is no suitable local soil with which at least a stable and impermeable embankment core can be formed, it must be brought to the site at extra cost and the local soil, if suitable, used for the embankment slopes.

Ideally, embankments should be constructed from the soil excavated from the site, and there should be a balance between cut and fill, although it is worth noting that ponds constructed completely in cut may be a cheaper alternative, especially if embankment construction costs are high. The soil used for embankment construction should be compacted in 150-250 mm layers to 90% of the maximum dry density as determined by the modified Proctor test. Shrinkage of the soil occurs during compaction (10-30 percent) and excavation estimates must take this into account. After compaction, the soil should have a coefficient of permeability, as determined *in situ*, of  $<10^{-7}$  m/s (see Section 5.3). Wherever possible, and particularly at large pond

installations, embankment design should allow for vehicle access to facilitate maintenance.

Embankment slopes are commonly 1 to 3 internally and 1 to 1.5-2 externally. Steeper slopes may be used if the soil is suitable; slope stability should be ascertained according to standard soil mechanics procedures for small earth dams. Embankments should be planted with grass to increase stability: a slow-growing rhizomatous species should be used to minimise maintenance (see Section 6.2).

External embankments should be protected from stormwater erosion by providing adequate drainage. Internal embankments require protection against erosion by wave action, and this is best achieved by precast concrete slabs (Figure 5.1) or stone rip-rap (Figure 5.2) at top water level. Such protection also prevents vegetation from growing down the embankment into the pond, so preventing the development of a suitable habitat for mosquito or snail breeding.

### 5.3 HYDRAULIC BALANCE

To maintain the liquid level in the ponds, the inflow must be at least greater than net evaporation and seepage at all times. Thus:

$$Q_i \geq 0.001A(e + s) \quad (5.1)$$

where  $Q_i$  = inflow to first pond,  $m^3/d$   
 $A$  = total area of pond series,  $m^2$   
 $e$  = net evaporation (i.e. evaporation less rainfall),  $mm/d$   
 $s$  = seepage,  $mm/d$

Seepage losses must be at least smaller than the inflow less net evaporation so as to maintain the water level in the pond. The maximum permissible permeability of the soil layer making up the pond base can be determined from d'Arcy's law:

$$k = [Q_s / (86,400A)] [\Delta l / \Delta h] \quad (5.2)$$

where  $k$  = maximum permissible permeability,  $m/s$   
 $Q_s$  = maximum permissible seepage flow  
 (=  $Q_i - 0.001Ae$ ),  $m^3/d$   
 $A$  = base area of pond,  $m^2$   
 $\Delta l$  = depth of soil layer below pond base to aquifer or more permeable stratum,  $m$   
 $\Delta h$  = hydraulic head (= pond depth +  $\Delta l$ ),  $m$



**Figure 5.1** Embankment protection by precast concrete slabs laid at top water level.



**Figure 5.2** Embankment protection by stone rip-rap.

If the permeability of the soil is more than the maximum permissible, the pond must be lined. A variety of lining materials is available and local costs dictate which should be used. Satisfactory lining has been achieved with ordinary portland cement (8 kg/m<sup>2</sup>), plastic membranes (Figures 5.3 and 5.4) and 150-300 mm layers of low-permeability soil. As a general guide, the following interpretations may be placed on values obtained for the *in situ* coefficient of permeability:

$k > 10^{-6}$  m/s: the soil is too permeable and the ponds must be lined;

$k > 10^{-7}$  m/s: some seepage may occur but not sufficiently to prevent the ponds from filling;

$k < 10^{-8}$  m/s: the ponds will seal naturally;

$k < 10^{-9}$  m/s: there is no risk of groundwater contamination (if  $k > 10^{-9}$  m/s and the groundwater is used for potable supplies, further detailed hydrogeological studies may be required).



**Figure 5.3** Anaerobic pond lined with an impermeable plastic membrane.

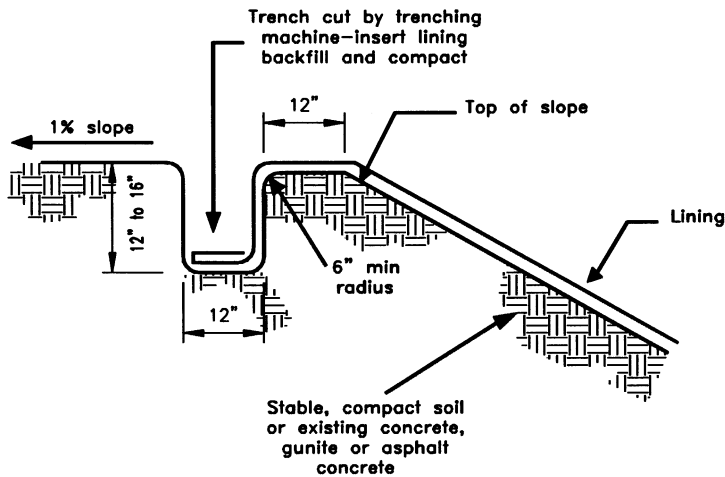

Figure 5.4  
Anchoring of pond  
lining at top of  
embankment  
(EPA, 1983).

## 5.4 PRELIMINARY TREATMENT

Adequate screening and grit removal facilities must be installed at all but very small systems (those serving <1000 people). Design should follow standard procedures (for example, IWEM, 1992; Marais, 1971; Marais and van Haandel, 1996; Metcalf & Eddy, Inc., 1991). Adequate provision must be made for the hygienic disposal of screenings and grit; haulage to a sanitary landfill or on-site burial in trenches are usually the most appropriate method.

Wastewater flows up to 6 times dry weather flow should be subjected to screening and grit removal. Any flows in excess of 6 DWF should be discharged via a stormwater overflow to a receiving watercourse. Anaerobic ponds should not receive more than 3 DWF, in order to prevent washout of acidogens and methanogens; so excess flows between 3 and 6 DWF are diverted via an overflow weir to the facultative ponds.

After screening and grit removal and, if installed, the >6 DWF overflow weir, the wastewater flow should be measured in a standard Venturi or Parshall flume. This is essential in order to assess pond performance (Section 7). Flow-recording devices may be installed, but these require careful calibration and regular maintenance. Often it is better to read the upstream channel depth from a calibrated brass rule and then calculate the flow from standard flume formulae (see IWEM, 1992; Metcalf & Eddy, Inc., 1991).

## 5.5 POND GEOMETRY

There has been little rigorous work done on determining optimal pond shapes. The most common shape is rectangular, although there is much variation in the length-to-breadth ratio. Clearly, the optimal pond geometry, which includes not only the shape of the pond but also the relative positions of its inlet and outlet, is that which minimises hydraulic short-circuiting.

In general, anaerobic and primary facultative ponds should be rectangular, with length-to-breadth ratios of 2 – 3 to 1 so as to avoid sludge banks forming near the inlet. Secondary facultative and maturation ponds should, wherever possible, have higher length-to-breadth ratios (up to 10 to 1) so that they better approximate plug flow conditions. Ponds do not need to be strictly rectangular, but may be gently curved if necessary or if desired for aesthetic reasons. A single inlet and outlet are usually sufficient, and these should be located just away from the base of the embankment in diagonally opposite corners of the pond (the inlet should *not* discharge centrally in the pond as this maximises hydraulic short-circuiting). The use of complicated multi-inlet and multi-outlet designs is unnecessary and not recommended.

To facilitate wind-induced mixing of the pond surface layers, the pond should be located so that its longest dimension (diagonal) lies in the direction of the prevailing wind. If this is seasonally variable, the wind direction in the hot season should be used as this is when thermal stratification is at its greatest. To minimise hydraulic short-circuiting, the inlet should be located such that the wastewater flows in the pond against the wind.

The areas calculated by the process design procedure described in Section 4 are mid-depth areas, and the dimensions calculated from them are thus mid-depth dimensions. These need to be corrected for the slope of the embankment, as shown in Figure 5.5.

A more precise method is advisable for anaerobic ponds, as these are relatively small. The following formula is used (EPA, 1983):

$$V_a = [(LW) + (L-2sD)(W-2sD) + 4(L-sD)(W-sD)] [D/6] \quad (5.3)$$

where  $V_a$  = anaerobic pond volume,  $m^3$

$L$  = pond length at TWL, m

$W$  = pond width at TWL, m

$s$  = horizontal slope factor (i.e. a slope of 1 in  $s$ )

$D$  = pond liquid depth, m

With the substitution of  $L$  as  $nW$ , based on a length to breadth ratio of  $n$  to 1, equation 5.3 becomes a simple quadratic in  $W$ .

The dimensions and levels that the contractor needs to know are those of the base and the top of the embankment; the latter includes the effect of the freeboard. The minimum freeboard that should be provided is decided on the basis of preventing waves, induced by the wind, from overtopping the embankment. For small ponds (under 1 ha in area) 0.5 m freeboard should be provided; for ponds between 1 ha and 3 ha, the freeboard should be 0.5-1 m, depending on site considerations. For larger ponds, the freeboard may be calculated from the equation (Oswald, 1975):

$$F = (\log_{10}A)^{1/2} - 1 \quad (5.4)$$

where  $F$  = freeboard, m

$A$  = pond area at TWL,  $m^2$

Pond liquid depths are commonly in the following ranges:

- anaerobic ponds: 2-5 m
- facultative ponds: 1-2 m
- maturation ponds: 1-1.5 m

The depth chosen for any particular pond depends on site considerations (presence of shallow rock, minimisation of earthworks). The depth of facultative and maturation ponds should not be less than 1 m so as to avoid vegetation growing up from the pond base, with the consequent hazard of mosquito and snail breeding.

At WSP systems serving more than around 10,000 people, it is often sensible (so as to increase operational flexibility) to have two or more series of ponds in parallel. The available site

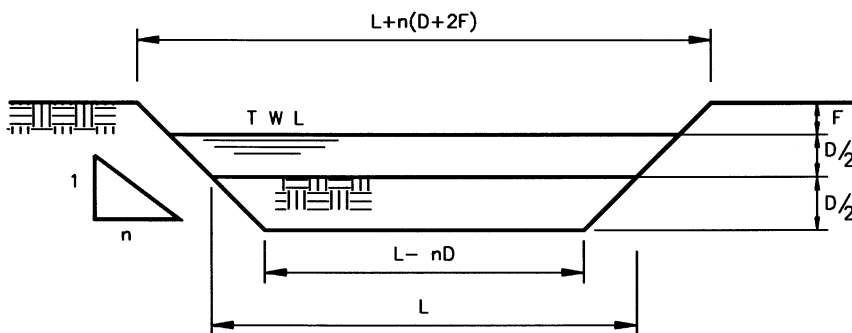

Figure 5.5 Calculation of top and bottom pond dimensions from those based on mid-depth.



topography may in any case necessitate such a subdivision, even for smaller systems. Usually the series are equal, that is to say they receive the same flow, and arrangements for splitting the raw wastewater flow into equal parts after preliminary treatment must be made (see Stalzer and von der Emde, 1972). This is best done by providing weir penstocks ahead of each series.

## 5.6 INLET AND OUTLET STRUCTURES

There is a wide variety of designs for inlet and outlet structures, and provided they follow certain basic concepts, their precise design is relatively unimportant. Firstly, they should be simple and inexpensive; while this should be self-evident, it is all too common to see unnecessarily complex and expensive structures. Secondly, they should permit samples of the pond effluent to be taken with ease. The inlet to anaerobic and primary facultative ponds should discharge well below the liquid level so as to minimise short-circuiting (especially in deep anaerobic ponds) and thus reduce the quantity of scum (which is important in facultative ponds). Inlets to secondary facultative and maturation ponds should also discharge below the liquid level, preferably at mid-depth in order to reduce the possibility of short-circuiting. Some simple inlet designs are shown in Figures 5.6 and 5.7.

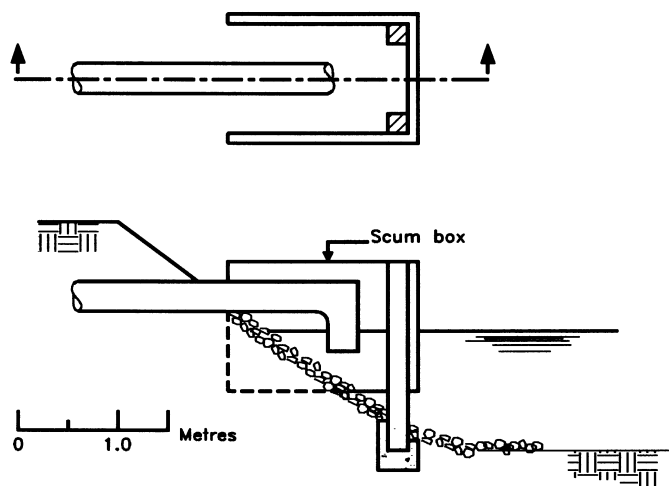

**Figure 5.6** Inlet structure for anaerobic and primary facultative ponds. The scum box retains most of the floating solids, so easing pond maintenance (ALTB/CTGREF, 1979).

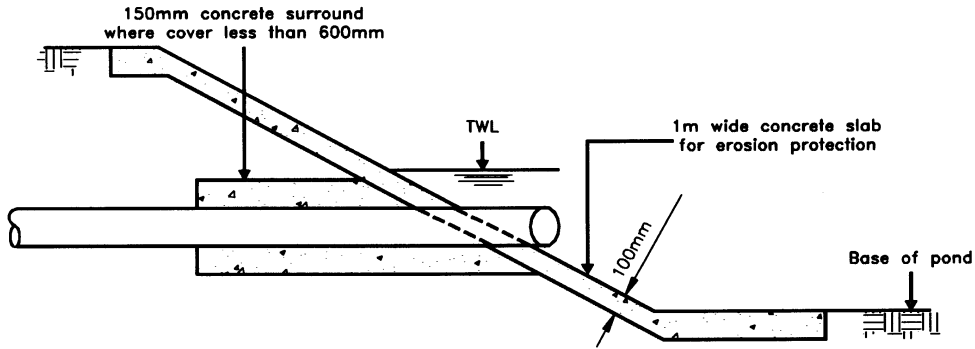

**Figure 5.7** Inlet structure for secondary facultative and maturation ponds. This would receive the discharge from the outlet structure shown in Figure 5.8.

The outlet of all ponds should be protected against the discharge of scum by the provision of a scum guard. The take-off level for the effluent, which is controlled by the scum guard depth, is important as it has a significant influence on effluent quality. In facultative ponds, the scum guard should extend just below the maximum depth of the algal band when the pond is stratified so as to minimize the daily quantity of algae, and hence BOD, leaving the pond. In anaerobic and maturation ponds, where algal banding is irrelevant, the take-off should be nearer the surface: in anaerobic ponds it should be well above the maximum depth of sludge but below any surface crust, and in maturation ponds it should be at the level that gives the best possible microbiological quality. The following effluent take-off levels are recommended:

anaerobic ponds:	300 mm
facultative ponds:	600 mm
maturation ponds:	50 mm

The installation of a variable height scum guard is recommended, since it permits the optimal take-off level to be set once the pond is operating.

A simple outlet weir structure is shown in Figure 5.8. The following formula should be used to determine the head over the weir and so, knowing the pond depth, the required height of the weir above the pond base can be calculated:

$$q = 0.0567 h^{3/2} \quad (5.5)$$

where  $q$  = flow per metre length of weir, l/s  
 $h$  = head of water above weir, mm

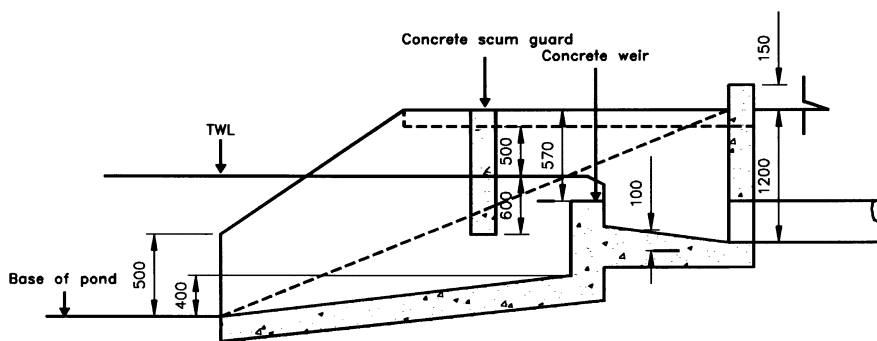

**Figure 5.8** Outlet weir structure. The weir length is calculated from equation 5.5. The discharge pipe would connect with the inlet structure shown in Figure 5.7. The concrete scum guard depth should be as described in Section 5.6 (here it is 600 mm, suitable for facultative ponds). As an alternative a variable-depth wooden scum guard may be used.

The outlet from the final pond in a series should discharge into a simple flow-measuring device such as a triangular or rectangular notch. Since the flow into the first pond is also measured, this permits the rate of evaporation and seepage to be calculated or, if evaporation is measured separately, the rate of seepage.

## 5.7 BY-PASS PIPEWORK

It is necessary to bypass anaerobic ponds so that facultative ponds may be commissioned first (see Section 6.1) and also during desludging operations (Section 6.3). Figure 5.9 shows schematically a by-pass arrangement for two series of WSP in parallel.

## 5.8 RECIRCULATION

If the incoming raw wastewater is septic, it may be necessary to achieve odour control by recirculating up to 50 percent of the final effluent. This should be pumped back and mixed with the raw wastewater immediately after preliminary treatment (i.e. before the wastewater enters the first pond). The final effluent acts to oxygenate the septic wastewater, and it may help to increase BOD removal. The process design of the ponds has to be altered to allow for the recirculated flow, and clearly recirculation, with its attendant problems of pump O&M, should only be considered as a measure of the last resort.

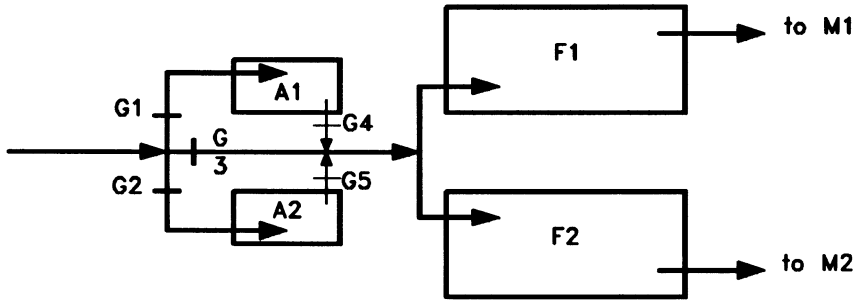

**Figure 5.9** By-pass pipework for anaerobic ponds. During normal operation gates G1 and G3 are open and gates G2 and G4 closed. To by-pass one (or both) of the anaerobic pond(s) gates G1 and G3 are closed and gate G2 and one (or both) of gates G4 open.

## 5.9 TREEBELT

In desert areas a treebelt should be provided to prevent wind-blown sand from being deposited in the ponds. Treebelts may also be desired for aesthetic reasons if the WSP site is close to human habitation. They should be planted upwind of the WSP and comprise up to five rows, as follows (from the upwind side):

- (a) 1-2 rows of mixed shrubs (<5 m) such as *Acacia bivenosa*, *Zizyphus spina-christi*, *Hibiscus* and *Nerium oleander*, none of which is eaten by goats;
- (b) 1-2 rows of 5-15 m tall trees such as *Acacia salicina*, *Cassia siamea*, *Sesbania grandiflora* and *Zizyphus mauritania*; and
- (c) 1 row of mixture of taller (>15 m) trees such as *Acacia mearnsii*, *Albizia lebbek*, *Casuarina equisetifolia*, *Casuarina cristata* and *Terminalia catappa*.

Local botanists will be able to advise on which species are most appropriate; those given above are suitable for use in northwest India. Such a treebelt is around 40-60 m wide.

## 5.10 SECURITY

Ponds (other than very remote installations) should be surrounded by a chain-link fence and gates should be kept padlocked.

Warning notices, in English, Hindi and the appropriate local language(s), attached to the fence and advising that the ponds are a wastewater treatment facility, and therefore potentially hazardous to health, are essential to discourage people from visiting the ponds, which if properly maintained (see Section 6) should appear as pleasant, inviting bodies of water. Children are especially at risk, as they may be tempted to swim in the ponds. Birdwatchers and hunters are also attracted to ponds by the often rich variety of wildlife, and they may not be aware that the ponds are treating wastewater.

### **5.11 OPERATOR FACILITIES**

The facilities to be provided for the team of pond operators depend partly on their number (see Section 6.3), but would normally include the following:

- (a) first-aid kit (which should include a snake bite kit);
- (b) strategically placed lifebuoys;
- (c) wash-basin and toilet; and
- (d) storage space for protective clothing, grass-cutting and scum-removal equipment, screen rakes and other tools, sampling boat (if provided) and life-jackets.

With the exception of the lifebuoys, these can be accommodated in a simple building. This can also house, if required, sample bottles and a refrigerator for sample storage. Laboratory facilities, offices and a telephone may also be provided at large installations. Adequate space for car parking should be provided.

At very large WSP sites consideration should also be given to providing housing for the relatively large number of operators employed.

